

**Sizes S, M, L;** Finished bust approx. 40 (44, 50)"; hem 20" wider

**Materials:**

- 2 packs Prism Merino Mia Gradient
- Needles size 3 & 5 or size to get gauge
- 40" circular size 5
- Stitch markers

**Gauge:** In stockinette st on larger needle 24 sts & 28 rows = 4"

**Chevron Pattern:** multiple of 25 (27, 29) plus 2

**Row 1:** K 6, \*ssk, k 5 (6, 7), (k 1, yo, k 1 in same st), k 5, (6, 7), k 2 tog, k 10\*, work\*\* 6 times, end ssk, k 5, (6, 7) (k 1, yo, k 1 in same st), k 5, (6, 7), k 2 tog, k 6.

**Row 2:** Purl.

**Back:** With smaller needle and Color 8, CO 177 (191, 205) sts. Knit 9 rows.

**Next row:** Establish patt: place markers (pm) as follows: K 6, pm, [k 15 (17, 19), pm, k 10, pm] 5 times; end k 15 (17, 19), pm, k 6.

Next row (RS) begin Chevron Patt with Row 1 and larger needle. Work even to 3.5". Join Color 7 and alternate 2 rows ea Colors 7 & 8 to 4.5" Cut Color 8 and cont with Color 7 to 7". Join Color 6 and alternate 2 rows ea Colors 6 & 7 to 8".

**First Decrease row:** k 4, k 2 tog, \*ssk, k 5 (k 6, k 7), (k 1, yo, k 1 in same st), k 5, (k 6, k 7), k 2 tog, ssk, k 6, k 2 tog\*, work\*\* 6 times, end ssk, k 5 (k 6, k 7), (k 1, yo, k 1 in same st), k 5, (k 6, k 7), k 2 tog, ssk, k 4—163 (177, 191) sts.

Cut Color 7 and cont in patt with Color 6 to 11". Join Color 5 and alternate 2 rows ea of Colors 6 & 5 to 12". Cut Color 6 and cont in patt with Color 5 to 15".

Join Color 4 and alternate 2 rows ea Colors 4 & 5 to 16".

**Second Decrease row:** k 3, k 2 tog, \*ssk, k 5 (k 6, k 7), (k 1, yo, k 1 in same st), k 5, (k 6, k 7), k 2 tog, ssk, k 4, k 2 tog\*, work\*\* 6 times, end with ssk, k 5 (k 6, k 7), (k 1, yo, k 1 in same st), k 5, (k 6, k 7), k 2 tog, ssk, k 3—149 (163, 177) sts.

Cut Color 5 and cont on Color 4 in patt to 19".

Join Color 3 and alternate 2 rows ea Colors 3 & 4 to 20".

**Third Decrease row:** k 2, k 2 tog, \*ssk, k 5 (k 6, k 7), (k 1, yo, k 1 in same st), k 5, (k 6, k 7), k 2 tog, ssk, k 2, k 2 tog\*, work \*\* 6 times, end ssk, k 5 (k 6, k 7), (k 1, yo, k 1 in same st), k 5, (k 6, k 7), k 2 tog, ssk, k 2—135 (149, 163) sts.

Cut Color 4 and cont on Color 3 in pattern to 23".

**Fourth Decrease row:** k 1, k 2 tog, \*ssk, k 5 (k 6, k 7), (k 1, yo, k 1 in same st), k 5, (k 6, k 7), k 2 tog, ssk, k 2 tog\*, work \*\* 6 times, end ssk, k 5 (k 6, k 7), (k 1, yo, k 1 in same st), k 5, (k 6, k 7), k 2 tog, ssk, k 1—121 (135, 149) sts.

Join Color 2 and alternate 2 rows ea Colors 2 & 3 to 24".

**Shape Armholes:** Cut Color 3 and cont with Color 2.

Bind off 8 (10, 11) sts beg next 2 rows, keeping to pattern as you are able (place markers at whole repeats)—105 (115, 127) sts.

Dec 1 st ea edge every other row 9 times—87 (97, 109) and at the same time at 27", join Color 1 and alternate 2 rows ea Colors 1 & 2 to 28".

Cont as est with Color 1 to 31 (31½, 32)". BO all sts firmly.



*Chevron sections separated by simple stockinette stitch give Brigitte's Nina Jacket a certain panache, enhanced by a gradation from deep smoky taupe to barely there color.*

**For fronts, match color changes to back.**

**Right Front:** With smaller needle and Color 8, CO 89, 95, 101 sts. Knit 9 rows.

**Next row:** Establish patt: K 6, pm, k 15 (17, 19), pm, k 10, pm, k 15 (17, 19) pm, k 10, pm, k 15 (17, 19) pm, k 10, pm, k 8.

Next row begin Pattern below with Row 1 and larger needle.

**Patt Row 1:** Inc 1 in first st, k 5, k 2 tog, k 10, \*ssk, k 5 (6, 7), (k 1, yo, k 1 in same st), k 5, (6, 7), k 2 tog, k 10\*, repeat \*\* once, end ssk, k 5, (6, 7) (k 1, yo, k 1 in same st), k 5, (6, 7), k 2 tog, k 6.

**Patt Row 2:** Purl.

Cont in patt to 8", ending ready for a RS row.

**First Decrease row:** Inc 1, k 5, k 2 tog, ssk, k 6, k 2 tog, \*ssk, k 5 (6, 7), (k 1, yo, k 1 in same st), k 5, (6, 7), k 2 tog, ssk, k 6, k 2 tog \*, repeat \*\* once, end ssk, k 5, (6, 7) (k 1, yo, k 1 in same st), k 5, (6, 7), k 2 tog, ssk, k 4—82 (88, 94) sts.

Cont in patt to 16”.

**Second Decrease row:** Inc 1, k 5, k 2 tog, ssk, k 4, k 2 tog, \*ssk, k 5 (6, 7), (k 1, yo, k 1 in same st), k 5, (6, 7), k 2 tog, ssk, k 4, k 2 tog \*, repeat \*\* once, end ssk, k 5, (6, 7) (k 1, yo, k 1 in same st), k 5, (6, 7), k 2 tog, ssk, k 3—75 (81, 87) sts.

Cont in patt to 19”.

**Third Decrease row:** Inc 1, k 5, k 2 tog, ssk, k 2, k 2 tog, \*ssk, k 5 (6, 7), (k 1, yo, k 1 in same st), k 5, (6, 7), k 2 tog, ssk, k 2, k 2 tog \*, repeat \*\* once, end ssk, k 5, (6, 7) (k 1, yo, k 1 in same st), k 5, (6, 7), k 2 tog, ssk, k 2—68 (74, 80) sts.

Cont in patt to 20”.

**Fourth Decrease row:** Inc 1, k 5, k 2 tog, ssk, k 2 tog, \*ssk, k 5 (6, 7), (k 1, yo, k 1 in same st), k 5, (6, 7), k 2 tog, ssk, k 2 tog \*, repeat \*\* once, end ssk, k 5, (6, 7) (k 1, yo, k 1 in same st), k 5, (6, 7), k 2 tog, ssk, k 1—61 (67, 73) sts.

Cont in patt to 24”, end ready for a WS row.

**Shape Armhole: WS row:** BO 8 (10, 11) sts, p to end—53 (57, 62) sts.

**All RS rows:** work patt as established, keeping to pattern as you are able.

**WS rows:** P 2 tog beg every WS row 9 times—44 (48, 53) sts.

**Shape Neck:** You will now eliminate first half chevron and cont with three established chevron sections to shoulder.

**Next RS Row:** Ssk beg of row and again every 4<sup>th</sup> row 7 times, keeping remaining 3 chevron sections as est—37 (41, 46) sts.

**Every WS Row:** Purl.

**Next RS Row:** Ssk beg of row and every RS row 11 times—26 (30, 35) sts. BO all sts.

**Left Front:** With smaller needle CO 89, (95, 101) sts. Knit 9 rows.

**Next row:** Est patt: K 8, pm, k 10, pm, k 15 (17, 19), pm, k 10, pm, k 15 (17, 19), pm, k 10, pm, k 15 (17, 19), pm, k 6.

Next row begin Pattern below with Row 1 and larger needle.

**Patt Row 1:** K 6, \*ssk, k 5 (6, 7), (k 1, yo, k 1 in same st), k 5, (6, 7), k 2 tog, k 10\*, work \*\* three times, end k 2 tog, k 5, inc 1.

**Patt Row 2:** Purl.

Cont in patt to 8”, ending ready for a RS row.

**First Decrease row:** K 4, k 2 tog, \*ssk, k 5 (6, 7), (k 1, yo, k 1 in same st), k 5, (6, 7), k 2 tog, ssk, k 6, k 2 tog\*, work \*\* three times, end k 2 tog, k 5, inc 1—82 (88, 94) sts.

Cont in patt to 16”.

**Second Decrease row:** K 3, k 2 tog, \*ssk, k 5 (6, 7), (k 1, yo, k 1 in same st), k 5, (6, 7), k 2 tog, ssk, k 4, k 2 tog\*, work \*\* three times, end k 2 tog, k 5, inc 1—75 (81, 87) sts.

Cont in patt to 19”.

**Third Decrease row:** K 2, k 2 tog, \*ssk, k 5 (6, 7), (k 1, yo, k 1 in same st), k 5, (6, 7), k 2 tog, ssk, k 2, k 2 tog\*, work \*\* three times, end k 2 tog, k 5, inc 1—68 (74, 80) sts. Cont in patt to 20”.

**Fourth Decrease row:** K 1, k 2 tog, \*ssk, k 5 (6, 7), (k 1, yo, k 1 in same st), k 5, (6, 7), k 2 tog, ssk, k 2 tog\*, work \*\* three times, end k 2 tog, k 5, inc 1—61 (67, 73) sts. Cont in patt to 24”.

**Shape Armhole: RS row:** BO 8 (10, 11) sts, work patt as est to end—53 (57, 62) sts.

**WS rows:** Purl.

**Next RS row:** Ssk beg every RS row 9 times, keeping remaining 3 chevron sections as est—44 (48, 53) sts.

**Shape Neck:** You will now eliminate first half chevron and cont with three established chevron sections to shoulder.

**Next WS row:** Ssp beg of row and again every 4<sup>th</sup> row 7 times—37 (41, 46) sts.

**Every RS Row:** Work in patt to last marker and knit to end.

**Next WS row:** Ssp beg every other row 11 times—26 (30, 35) sts. BO all sts.

**Sleeves:**

With larger needles and Color 6, CO 49 (53, 63) sts. Knit 9 rows.

**Next row:** Est patt: place markers as follows: K 17 (18, 22), pm, k 15 (17, 19), pm, k 17 (18, 22).

**Row 1:** K 16 (18, 22), ssk, k 5 (6, 7), (k 1, yo, k 1) in same st, k 5, (6, 7), k 2 tog, k 16 (18, 22).

**Row 2:** Purl.

From this point, as you work increases as stated below, at 1.75”, join Color 5 and work color gradation from this point on to match body.

Inc 1 st beg and end every 4<sup>th</sup> row 15 times, keeping sts between markers in patt and working all new sts in stockinette—79 (83, 93) sts.

Inc 1 st beg and end every 6<sup>th</sup> row 7 times—93 (97, 107) sts.

Work to 16 (16.5, 17)” or desired length to underarm.

**Shape Cap:** Cont in patt as est.

BO 12 sts at beg of next two rows—69 (73, 83) sts.

Dec 1 st ea end of every RS row 26 (28, 30) times—17 (17, 23) sts.

BO remaining sts.

**Finishing:**

Sew shoulder seams, taking care to match front and back. Sew sleeves to armholes. Sew side and sleeve seams.

**Front and Neck Band:** With 40” circular size 5 needles and Color 8, beg at lower RF edge, pick up & knit 198 (200, 204) sts to shoulder; 38 sts across back neck; & 198 (200, 204) sts to lower LF edge. Knit 1 row.

Knit 2 rows ea Color 7, 6, 5, 4, 3, 2.

Knit 1 row Color 1.

BO all sts evenly with WS facing (check as you go to make sure they are not pulling tight or ruffling).

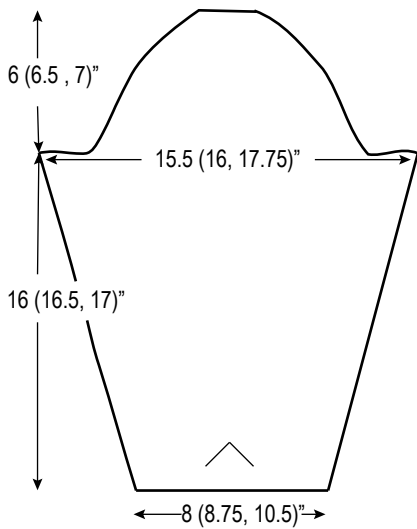
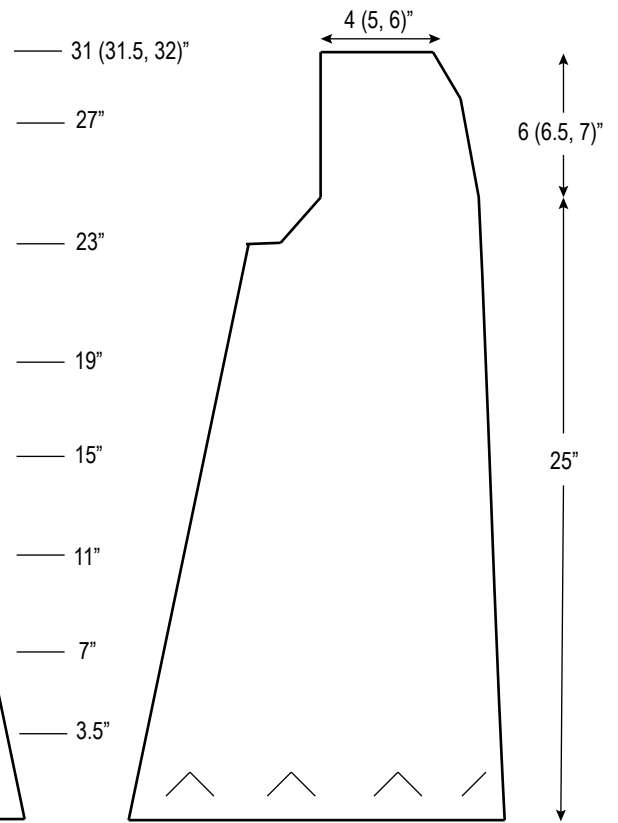
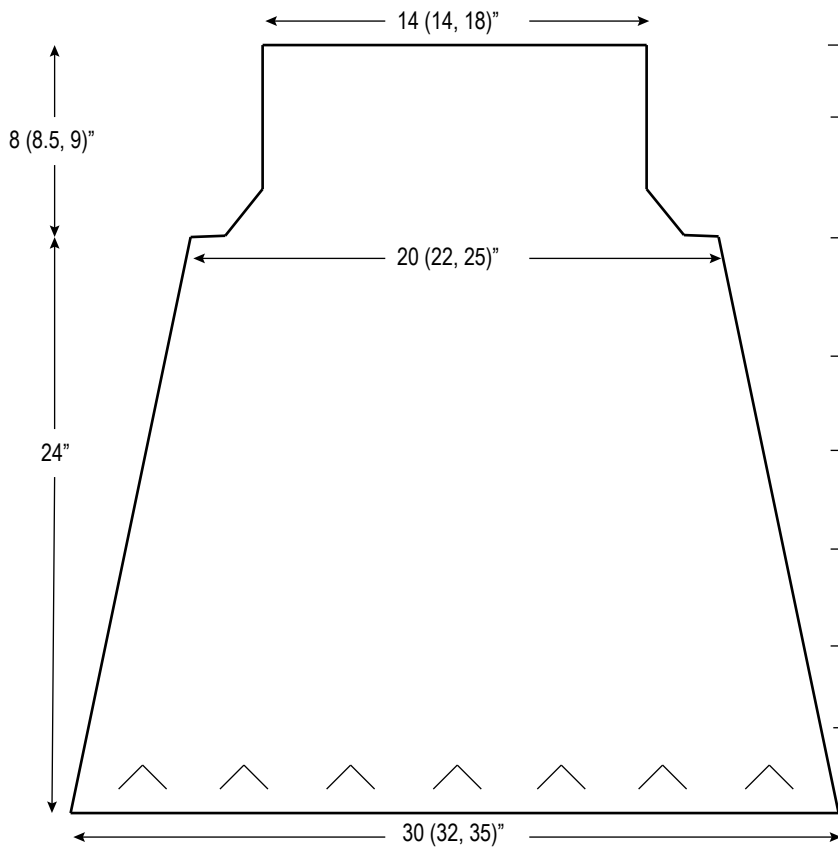

*When the bias knitting of a chevron wedge meets stockinette, the natural tendency of stockinette to roll toward the purl side creates a gentle cascade of soft pleats that swing when you walk. A true swing jacket, indeed!*



