

Sizes S, M, L; Finished bust approx. 40 (44, 50)"; hem 20" wider

Materials:

10 (12, 14) Prism Merino Mia
Needles size 3 & 5 or size to get gauge
40" circular size 5
Stitch markers

Gauge: In stockinette st on larger needle 24 sts & 28 rows = 4"

Chevron Pattern: multiple of 25 (27, 29) plus 2

Row 1: K 6, *ssk, k 5 (6, 7), (k 1, yo, k 1 in same st), k 5, (6, 7),
k 2 tog, k 10*, work** 6 times, end ssk, k 5, (6, 7)
(k 1, yo, k 1 in same st), k 5, (6, 7), k 2 tog, k 6.

Row 2: Purl.

Back: With smaller needle, CO 177 (191, 205) sts. Knit 9 rows.

Next row: Establish patt: place markers (pm) as follows: K 6, pm,
[k 15 (17, 19), pm, k 10, pm] 6 times; end k 15 (17, 19),
pm, k 6.

Next row (RS) begin Chevron Patt with Row 1 and larger needle.
Work even to 8".

First Decrease row: k 4, k 2 tog, *ssk, k 5 (k 6, k 7), (k 1, yo, k 1 in
same st), k 5, (k 6, k 7), k 2 tog, ssk, k 6, k 2 tog*, work** 6 times,
end ssk, k 5 (k 6, k 7), (k 1, yo, k 1 in same st), k 5, (k 6, k 7), k 2
tog, ssk, k 4—163 (177, 191) sts.

Cont in pattern as now established to 16".

Second Decrease row: k 3, k 2 tog, *ssk, k 5 (k 6, k 7), (k 1, yo, k 1
in same st), k 5, (k 6, k 7), k 2 tog, ssk, k 4, k 2 tog*, work** 6
times, end with ssk, k 5 (k 6, k 7), (k 1, yo, k 1 in same st), k 5,
(k 6, k 7), k 2 tog, ssk, k 3—149 (163, 177) sts.

Cont in pattern as now established to 19".

Third Decrease row: k 2, k 2 tog, *ssk, k 5 (k 6, k 7), (k 1, yo, k 1 in
same st), k 5, (k 6, k 7), k 2 tog, ssk, k 2, k 2 tog*, work ** 6
times, end ssk, k 5 (k 6, k 7), (k 1, yo, k 1 in same st), k 5, (k 6,
k 7), k 2 tog, ssk, k 2—135 (149, 163) sts.

Cont in pattern as now established to 20"

Fourth Decrease row: k 1, k 2 tog, *ssk, k 5 (k 6, k 7), (k 1, yo, k 1
in same st), k 5, (k 6, k 7), k 2 tog, ssk, k 2 tog*, work ** 6 times,
end ssk, k 5 (k 6, k 7), (k 1, yo, k 1 in same st), k 5, (k 6, k 7), k 2
tog, ssk, k 1—121 (135, 149) sts.

Cont in pattern as now established to 23".

Shape Armholes:

Bind off 8 (10, 11) sts beg next 2 rows, keeping to pattern as you
are able (place markers at whole repeats)—105 (115, 127) sts.
Dec 1 st ea edge every other row 9 times—87 (97, 109).

Cont as est to 31 (31½, 32)". BO all sts firmly.

Right Front: With smaller needle CO 89, 95, 101 sts.

Knit 9 rows.

Next row: Establish patt: K 6, pm, k 15 (17, 19), pm, k 10, pm, k 15
(17, 19) pm, k 10, pm, k 15 (17, 19) pm, k 10, pm, k 8.

Next row begin Pattern below with Row 1 and larger needle.

Patt Row 1: Inc 1 in first st, k 5, k 2 tog, k 10, *ssk, k 5 (6, 7),
(k 1, yo, k 1 in same st), k 5, (6, 7), k 2 tog, k 10*,
repeat ** once, end ssk, k 5, (6, 7) (k 1, yo, k 1 in
same st), k 5, (6, 7), k 2 tog, k 6.



*Merino Mia opened up to a slightly larger gauge works up with superior drape in Brigitte's Nina Jacket.
Chevron sections are separated by simple stockinette stitch.*

Patt Row 2: Purl.

Cont in patt to 8", ending ready for a RS row.

First Decrease row: Inc 1, k 5, k 2 tog, ssk, k 6,
k 2 tog, *ssk, k 5 (6, 7), (k 1, yo, k 1 in same st), k 5,
(6, 7), k 2 tog, ssk, k 6, k 2 tog *, repeat ** once, end
ssk, k 5, (6, 7) (k 1, yo, k 1 in same st), k 5, (6, 7), k 2
tog, ssk, k 4—82 (88, 94) sts.

Cont in patt as now established to 16".

Second Decrease row: Inc 1, k 5, k 2 tog, ssk,
k 4, k 2 tog, *ssk, k 5 (6, 7), (k 1, yo, k 1 in same st),
k 5, (6, 7), k 2 tog, ssk, k 4, k 2 tog *, repeat ** once,
end ssk, k 5, (6, 7) (k 1, yo, k 1 in same st), k 5, (6, 7),
k 2 tog, ssk, k 3—75 (81, 87) sts.

Cont in patt as now established to 19".

Third Decrease row: Inc 1, k 5, k 2 tog, ssk, k 2,
k 2 tog, *ssk, k 5 (6, 7), (k 1, yo, k 1 in same st), k 5,
(6, 7), k 2 tog, ssk, k 2, k 2 tog *, repeat ** once, end
ssk, k 5, (6, 7) (k 1, yo, k 1 in same st), k 5, (6, 7),
k 2 tog, ssk, k 2—68 (74, 80) sts.

Cont in patt as now established to 20".

Fourth Decrease row: Inc 1, k 5, k 2 tog, ssk, k 2 tog, *ssk, k 5 (6, 7), (k 1, yo, k 1 in same st), k 5, (6, 7), k 2 tog, ssk, k 2 tog*, repeat ** once, end ssk, k 5, (6, 7) (k 1, yo, k 1 in same st), k 5, (6, 7), k 2 tog, ssk, k 1—61 (67, 73) sts.

Cont in patt as now established to 23", end ready for a WS row.

Shape Armhole: WS row: BO 8 (10, 11) sts, p to end—53 (57, 62) sts.

All RS rows: work patt as established, keeping to pattern as you are able.

WS rows: P 2 tog beg every WS row 9 times—44 (48, 53) sts.

Shape Neck: You will now eliminate first half chevron and cont with three established chevron sections to shoulder.

Next RS Row: Ssk beg of row and again every 4th row 7 times, keeping remaining chevron sections as est—37 (41, 46) sts.

Every WS Row: Purl.

Next RS Row: Ssk beg of row and every RS row 11 times—26 (30, 35) sts. BO all sts.

Left Front: With smaller needle CO 89, (95, 101) sts. Knit 9 rows.

Next row: Est patt: K 8, pm, k 10, pm, k 15 (17, 19), pm, k 10, pm, k 15 (17, 19), pm, k 10, pm, k 15 (17, 19), pm, k 6.

Next row: begin Pattern below with Row 1 and larger needle.

Patt Row 1: K 6, *ssk, k 5 (6, 7), (k 1, yo, k 1 in same st), k 5, (6, 7), k 2 tog, k 10*, work ** three times, end k 2 tog, k 5, inc 1.

Patt Row 2: Purl.

Cont in patt to 8", ending ready for a RS row.

First Decrease row: K 4, k 2 tog, *ssk, k 5 (6, 7), (k 1, yo, k 1 in same st), k 5, (6, 7), k 2 tog, ssk, k 6, k 2 tog*, work ** three times, end k 2 tog, k 5, inc 1—82 (88, 94) sts.

Cont in patt as now established to 16".

Second Decrease row: K 3, k 2 tog, *ssk, k 5 (6, 7), (k 1, yo, k 1 in same st), k 5, (6, 7), k 2 tog, ssk, k 4, k 2 tog*, work ** three times, end k 2 tog, k 5, inc 1—75 (81, 87) sts.

Cont in patt as now established to 19".

Third Decrease row: K 2, k 2 tog, *ssk, k 5 (6, 7), (k 1, yo, k 1 in same st), k 5, (6, 7), k 2 tog, ssk, k 2, k 2 tog*, work ** three times, end k 2 tog, k 5, inc 1—68 (74, 80) sts.

Cont in patt as now established to 20".

Fourth Decrease row: K 1, k 2 tog, *ssk, k 5 (6, 7), (k 1, yo, k 1 in same st), k 5, (6, 7), k 2 tog, ssk, k 2 tog*, work ** three times, end k 2 tog, k 5, inc 1—61 (67, 73) sts.

Cont in patt as now established to 23".

Shape Armhole: RS row: BO 8 (10, 11) sts, work patt as est to end—53 (57, 62) sts.

WS rows: Purl.

Next RS row: Ssk beg every RS row 9 times, keeping remaining 3 chevron sections as est—44 (48, 53) sts.

Shape Neck: You will now eliminate first half chevron and cont with three established chevron sections to shoulder.

Next WS row: Ssp beg of row and again every 4th row 7 times—37 (41, 46) sts.

Every RS Row: Work in patt to last marker and knit to end.

Next WS row: Ssp beg every other row 11 times—26 (30, 35) sts. BO all sts.

Sleeves:

With larger needles, CO 49 (53, 63) sts and knit 9 rows.

Next row: Est patt: place markers as follows: K 17 (18, 22), pm, k 15 (17, 19), pm, k 17 (18, 22).

Row 1: K 16 (18, 22), ssk, k 5 (6, 7), (k 1, yo, k 1) in same st, k 5, (6, 7), k 2 tog, k 16 (18, 22).

Row 2: Purl.

Inc 1 st beg and end every 4th row 15 times, keeping sts between markers in patt and working all new sts in stockinette—79 (83, 93) sts.

Inc 1 st beg and end every 6th row 7 times—93 (97, 107) sts.

Work to 16 (16 ½, 17)" or desired length to underarm.

Shape Cap: Cont in patt as est.

BO 12 sts at beg of next two rows—69 (73, 83) sts.

Dec 1 st ea end of every RS row 26 (28, 30) times—17 (17, 23) sts.

BO remaining sts.

Finishing:

Sew shoulder seams, taking care to match front and back. Sew sleeves to armholes. Sew side and sleeve seams.

Front and Neck Band: With 40" circular size 5 needles, beg at lower RF edge, pick up & knit 198 (200, 204) sts to shoulder; 38 sts across back neck; & 198 (200, 204) sts to lower LF edge.

Knit 14 rows. BO all sts evenly with WS facing.

Periodically hold work vertically to check that edge is not pulling tight or ruffling.

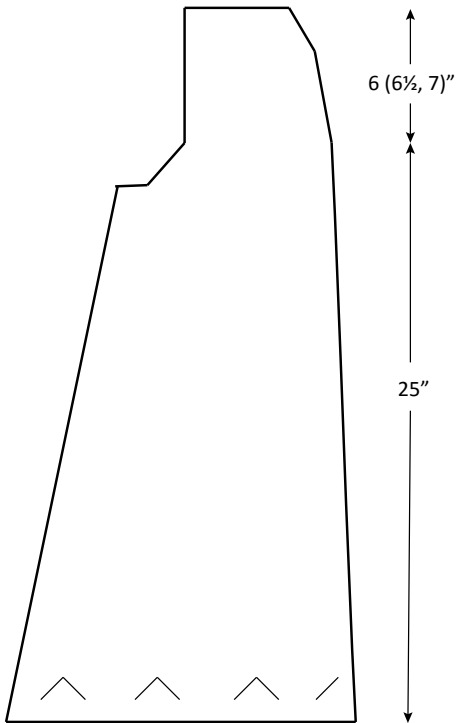
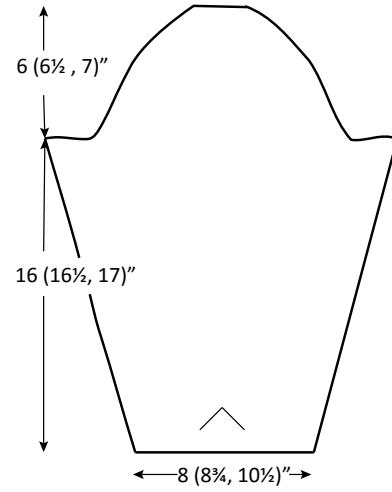
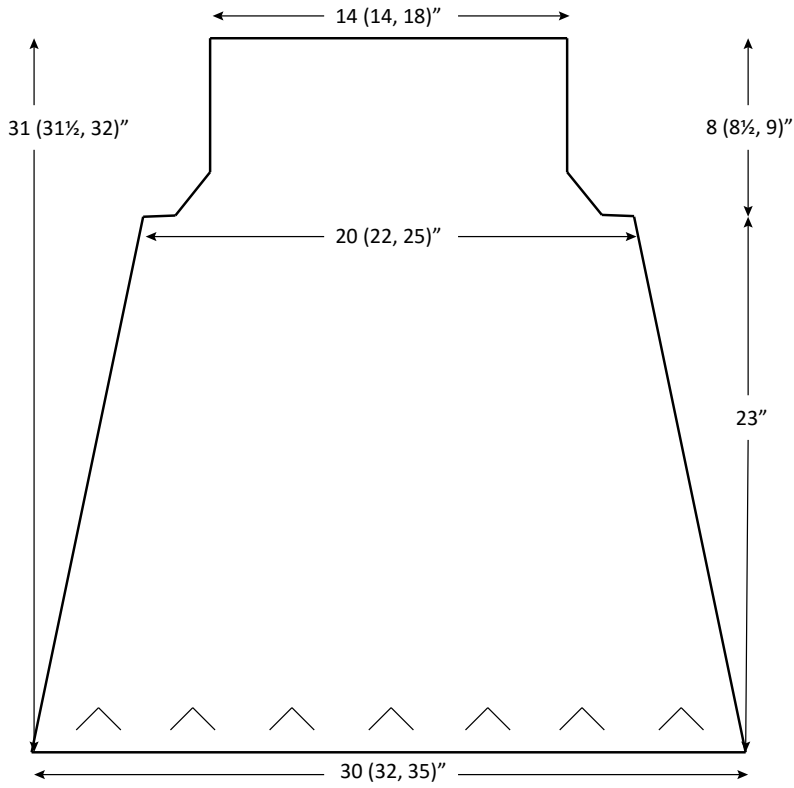

When the bias knitting of a chevron wedge meets stockinette, the natural tendency of stockinette to roll toward the purl side creates a gentle cascade of soft pleats that swing when you walk. A true swing jacket, indeed!